







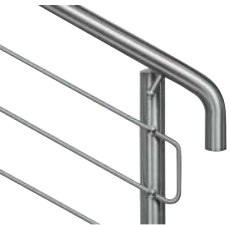

Contents

	The HEWI brand	Introduction	3
	Handrails and Balustrades Polyamide	True classics Product overview	5 6
			
	Handrails and Balustrades Stainless steel	Elegant effect Product overview	9 10
			
	Handrails Wood	Harmonious combination Product overview	13 14
	Handrail brackets Panel holders Fastening types		16 17 19
	HEWI colour system Services	Freedom of design Contact	22 23

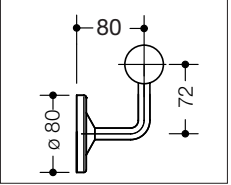

The HEWI brand

Future orientation routed in tradition

HEWI is a forward-looking company with a corporate history stretching back over 75 years and its UK division in the South of England.

The satisfaction of our customers and partners is our top priority. Meeting modern architectural demands is the motto underpinning all our products and services.

Our main product areas are:

- Barrierfree living
- Sanitary accessories
- Hardware
- Handrails and Balustrades

Our products accompany our customers throughout their lives. With this in mind, the product collections are mutually integrating and are held in stock for a long period of time. HEWI products can be enhanced and adapted, thus offering security in terms of planning and investment.

The Contracts Division offers a total supply and fix package for handrails and balustrades from initial conception through to final installation. The package includes technical advice, preparation of specifications, quotation, site measurement, autocad drawings, site fixing programme and project management through to final installation.



Handrails and Balustrades

Polyamide

Handrails and balustrades colour - true classics

The colour handrail and balustrade system from HEWI is available in 10 colours, thereby offering comprehensive design scope. The careful selection of colours enables the balustrade and handrails to provide orientation functionality.

The material used, polyamide, has homogeneous full colouring and is exceptionally pleasant to touch. The non-porous surface finishes are easy to clean. Colour is particularly well-suited for use in heavily frequented public areas such as educational institutions, hospitals and homes for the elderly.



Right page

Handrail and balustrade colour.

Handrails and Balustrades colour

Range features

Standards

Balustrades have been independently tested and satisfy the requirements of BS6180 and BS6399, as referred to in the Building Regulations Document K. Handrails are fully compliant with Approved Document M – 2004 Edition and BS.8300:2001.

Fire Resistance - DIN 4102

Steel: non-flammable (Building Materials Class A2).
Polyamide: normal flammability (Building Materials Class B2).

Technology

Handrails are made of 5 mm thick solid high quality polyamide sleeves coloured throughout in 10 standard colours with corrosion resistant steel core and are available in both 40 mm and 33 mm diameter. Balustrade uprights and top rails are 40 mm diameter only.

Wall mounted handrails with rose fixings are available with optional designs for the handrail brackets as illustrated on page 16. For all bracket types the maximum centres of the brackets are as follows: 1250 mm for 33 mm diameter, 1500 mm for 40 mm diameter.

Balustrades are available with 6 alternative fixing types for uprights to suite most conditions on staircases. These are fully illustrated on page 19.

Infill panels secured with clamp function panel holders are available in 10 mm toughened glass to BS6206 Class A in clear or tinted options.

We are also able to apply manifestations using acid etching or silk screen printing processes. Alternative infill panels are available in both colour coated perforated metal or stainless steel. Multirails in 40 mm or 33 mm diameter rail parallel to top rail may also be used in certain situations.

Upright distance maximum 1000 mm, railing height 900, 1000 or 1100 mm.

Applications

Educational institutions, hospitals, homes for the elderly and all public buildings with a high traffic area.

HEWI Basic colours

buttercup yellow (13), ruby red (33), coffee brown (80), ultramarine blue (53), steel blue (50)

HEWI Neutral colours

pure white (99), light grey (97), stone grey (95), anthracite grey (92), jet black (90)



13 33 80 53 50 99 97 95 92 90

Handrail options

CO.40.8100.W2

CO.33.8100.W2

CO.40.8101.W3

CO.40.8100.W11

CO.33.8100.W11

Balustrade options

End bends without roses
Bracket W2, W3, W7 (concealed fixing) or
Bracket W6 (visible fixing), ø 40 mm or ø 33 mm.



Straight handrail with end caps
Bracket W2, W3, W7 (concealed fixing) or
Bracket W6 (visible fixing), ø 40 mm or ø 33 mm.



End bends with rose fixing
Bracket W11 (bend bracket with concealed fixing),
ø 40 mm or ø 33 mm.



40.9100... Balustrade with colour coated perforated infill panel



40.9100... Balustrade with toughened safety glass infill panel



Handrails and Balustrades

Stainless steel

Circum - elegant effect

The circum handrail and balustrade system effortlessly fulfils the highest function and design standards.

The optional handrail materials available are stainless steel, hardwood or polyamide.

Stainless steel balustrades are available with perforated stainless steel panels, perforated powder coated stainless steel panels or toughened safety glass. Other options are also available for the infills.

Circum is a flexible system that provides the opportunity to create handrail and balustrade to staircase areas which are aesthetically pleasing and have lasting visual appeal.



Right page

Handrail and balustrade circum.

Handrails and Balustrades circum

Range features

Standards

Balustrades have been independently tested and satisfy the requirements of BS6180 and BS6399, as referred to in the Building regulations Document K. Handrails and top rails to balustrades are also available as an option to stainless steel in hardwood or coloured polyamide which then is fully compliant with approved Document M – 2004 Edition and BS.8300:2001.

Fire Resistance – DIN 4102

Stainless steel: non flammable (Building Materials Class A2).

Technology

Handrails and balustrades are assembled from standard components in compliance with ISO 9001 thus assuring the highest quality is achieved for every construction and providing easy installation on site.

Product Specifics

Circum handrails and balustrades are made of stainless steel with a high quality satin finish (240 grain) and concealed connections.

This system is made of grade 304 (1.4301) stainless steel as standard, grade 316L (1.4571) is also available upon request.

All handrails are 40 mm diameter. Wall fixed handrails 40 mm diameter are mounted on 90° brackets as illustrated on page 16. For all bracket types the maximum centre is 1700 mm.

Balustrades have 40 mm diameter top rails with 48,3 mm diameter uprights mounted on 135 mm diameter x 10 mm thick platform or side fixing plates.

Detailed sections of the fixing plates are illustrated on page 18.

Handrails and top rails to balustrades as an option to stainless steel are available in European hardwood timbers: beech, oak, and maple.

The rails are also available in polyamide in 10 standard colours. Upright distance maximum 1000 mm, railing height 900, 1000 or 1100 mm.

Various options are available for infill panels to balustrades. Infill panels secured with clamp function panel holders are available in 10 mm toughened glass to BS6206 Class A in clear or tinted options. We are also able to apply manifestations using acid etching or silk screen printing processes.

Multirails in 10 mm diameter stainless steel rods running parallel to top rail may also be used in certain situations.

Applications

Public buildings, industrial and commercial businesses, administration buildings as well as public and private housing.

Surface stainless steel



Handrail options

CI.40.8100.W6

CI.40.8101.W6

Balustrade options

90° return end, open tube
Bracket W6 (visible fixing) or
Bracket W7 (concealed fixing).



Straight end, sealed tube, with impact cover
(2 mm convexed),
Bracket W6 (visible fixing) or
Bracket W7 (concealed fixing).



CI.40.9902... Balustrade with parallel steel rods and timber top rail



CI.40.9101... Balustrade with toughened safety glass infill panel and stainless steel top rail

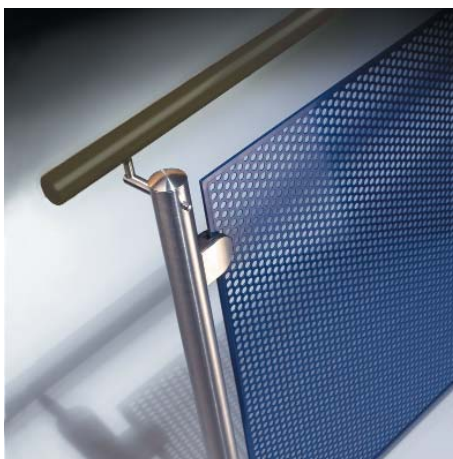

CI.40.9203... Balustrade with colour coated perforated infill panel and polyamide top rail

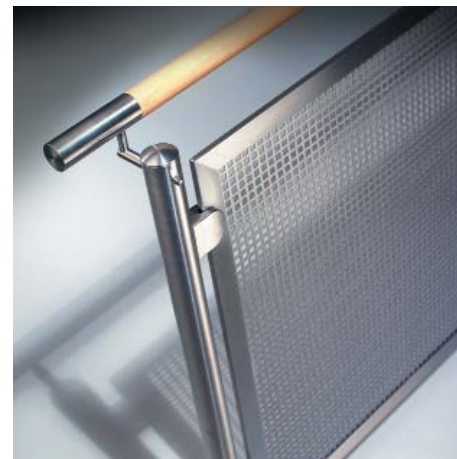

CI.40.9102... Balustrade with perforated stainless steel infill panel and timber top rail



	1
←	Library 
←	Cafeteria 
→	Lift 



Handrails

Wood

Handrail system lignum - Harmonious combination

The lignum handrail system is a modular system enabling the combination of various wooden handrails with brackets and bends made of polyamide and stainless steel. The available wood types are beech, oak and maple.

High durability with lignum protect

Lignum protect was designed for use in highly-frequented corridors subjected to hard use. It is a solid wood handrail in which a shockproof strip made of HPL has been inlaid.

This combines two advantages: It enables problem-free use of wood in this area to achieve a homely effect the impact-protected product prevents damage.

Bends and corners made of polyamide or stainless steel also increase the impact resistance at the ends and corners of the handrails and create good options for combination with other interior fit-out features within the building.

Integral look with lignum multiplex

Multiplex, a glued laminated wood, continues to be a popular choice. The extraordinary and characteristic striped look is a design feature, which can create a visual link with other interior design objects, e.g. furniture or doors.

Beech, maple and birch multiplex are available to choose from in combination with various stainless steel brackets.

Due to the glue fraction, multiplex has a comparatively higher strength than solid wood and is therefore more resistant against impact.



Right page

Handrail lignum, lignum protect and lignum multiplex.

Handrails lignum

Range features

Standards

Fully compliant with approved Document M- 2004 edition and BS.8300:2001.

Fire resistance - DIN 4102

Normal flammability (Building Materials Class B2).

Technology

Lignum is a high quality wall mounted handrail system made of 40 mm diameter solid European hardwoods, only A grade timber is used steamed and kiln dried.

The surface of the handrail is twice sanded and finished with 2 coats of clear protective varnish. All butt joints in the length of the rail have a 2 mm chamfer and are dowelled and glued to provide a strong connection.

All handrails are assembled from standard components with our own total quality management system assuring the highest quality is achieved for every construction, providing accurate and efficient installation on site.

Product Specifics

Lignum handrails are available in the following European hardwoods: beech, oak and maple. Other species are available upon request.

The bends to the rails are available in matching timber, stainless steel satin finish or coloured polyamide with handrail brackets in various designs.

The different designs of rose fixings and their reference codes are shown on the opposite page. Detailed sections of the handrail brackets are illustrated on page 16. For all bracket types the maximum centre of brackets is 1250 mm.

Lignum protect is complete with an insert strip made of HPL completed with a black and white core 10,6 mm deep projecting from the face of handrail to provide impact protection. Lignum protect has the added advantage of providing a wall protection system combined with a handrail which is fully compliant with Document M of the Building Regulations.

Lignum multiplex is a high-quality handrail system made of 'multiplex' maple (40 mm in diameter). The surface finishes are sanded twice and coated twice with a clear protective varnish. 'Multiplex' beech and birch as well as waxed finishes are available on request. Our proven connecting system comprising glued and screwed joints guarantees stable and visually perfect connections between bends, straight elements and supports.

Applications

Homes for the elderly, hospitals, schools and domestic housing.

Hardwoods

Maple, beech and oak.



Handrail options lignum

LI.40.8100.W3

LI.40.8101.W3

LI.40.8101.W3

LI.40.8800.W6

LI.40.8800.W6

Handrails lignum protect

LP.40.8700.W2

LP.40.8701.W3

Handrails lignum multiplex

LM.40.8100.W6

LM.40.8101.W3

End bends and bends at change of direction made of wood,
Bracket W3 (concealed fixing) or
Bracket W6 (visible fixing).



Ends with caps and bends at change of direction made of wood,
Bracket W3, W7 (concealed fixing) or
Bracket W6 (visible fixing).



Straight ends with chamfer, bends at change of direction made of wood,
Bracket W3, W7 (concealed fixing) or
Bracket W6 (visible fixing).



End bends and bends at change of direction made of stainless steel,
Bracket W3, W7 (concealed fixing) or
Bracket W6 (visible fixing).



End bends and elbow bends made of polyamide,
Bracket W2, W3, W7 (concealed fixing) or
Bracket W6 (visible fixing).



End bends and bends at change of direction made of polyamid,
Bracket W2, W3 (concealed fixing), or
Bracket W6 (visible fixing).



Straight end with wooden cap, bends at change of direction made of polyamide or stainless steel,
Bracket W2, W3 (concealed fixing), or
Bracket W6 (visible fixing).



End bends made of multiplex, bends at change of direction made of multiplex bend or stainless steel,
Bracket W3, W7 (concealed fixing) or
Bracket W6 (visible fixing).



Straight ends with chamfer, bends at change of direction made of multiplex bend or stainless steel,
Bracket W3, W7 (concealed fixing) or
Bracket W6 (visible fixing).



Handrail Brackets

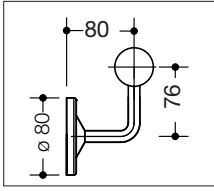

Bracket W2

As illustrated with 12 mm diameter curved satin stainless steel stem mounted on 80 mm diameter zinc plated steel inner fixing rose with 11 screw holes, complete with clip on polyamide outer cover from the standard HEWI colour range to conceal fixings.



W2

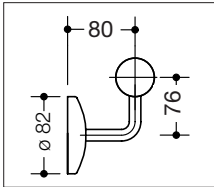

Bracket W3

As illustrated with 12 mm diameter curved satin stainless steel stem mounted on 80 mm diameter zinc-plated steel inner fixing rose with 3 screw holes, complete with clip on stainless steel outer cover to conceal fixings.



W3

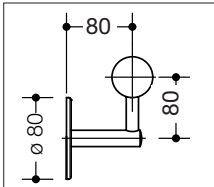

Bracket W6

As illustrated in satin stainless steel comprising of a 16 mm diameter horizontal arm and 12 mm vertical stem mounted on 80 mm diameter stainless steel rose with 2 holes for exposed screw fixings.



W6

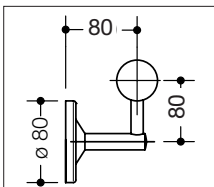

Bracket W7

As illustrated in satin stainless steel comprising of a 16 mm diameter horizontal arm and 12 mm vertical stem mounted on 80 mm diameter zinc plated steel inner fixing rose with 11 screw holes complete with clip on stainless steel outer cover to conceal fixings.



W7

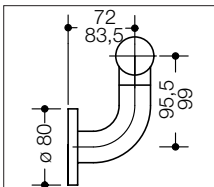

Bracket W11

As illustrated, seamless abrasion resistant polyamide, coloured throughout comprising of a 33 mm diameter bend mounted on 80 mm diameter zinc plated steel inner fixing rose with 11 screw holes, complete with clip on polyamide outer cover to conceal fixings.

The projection is approximately 64 mm with a 40 mm diameter handrail
The projection is approximately 56 mm with a 33 mm diameter handrail



W11

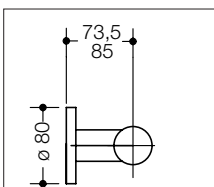

Bracket G11

As illustrated, seamless abrasion resistant polyamide, coloured throughout comprising of a 33 mm diameter straight section mounted on 80 mm diameter zinc plated steel inner fixing rose with 11 screw holes, complete with clip on polyamide outer cover to conceal fixings.

The projection is approximately 64 mm with a 40 mm diameter handrail
The projection is approximately 56 mm with a 33 mm diameter handrail



G11

**Panel holder 40.1155
40.1156**

Panel holder with removable polyamide cover and corrosion resistant steel insert, prepared to clamp 6, 8, 9.5, 10, 12 or 13 mm thick infill panels.

All infill panels require a torque of 12 Nm per clamp screw. A 2.5 mm gap between panel holder and infill panel should be allowed.

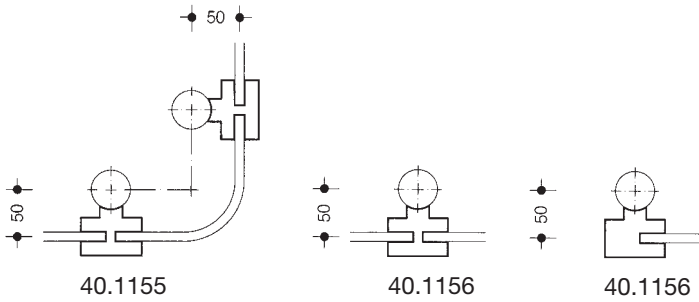
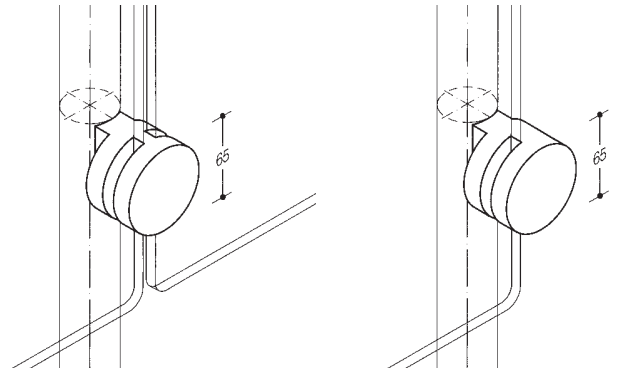

**Panel holder 40.1150
40.1151**

Panel holder with removable polyamide cover and corrosion resistant steel insert, prepared to clamp 6, 8, 9.5, 10, 12 or 13 mm thick infill panels.

All infill panels require a torque of 12 Nm per clamp screw. A 2.5 mm gap between panel holder and infill panel should be allowed.

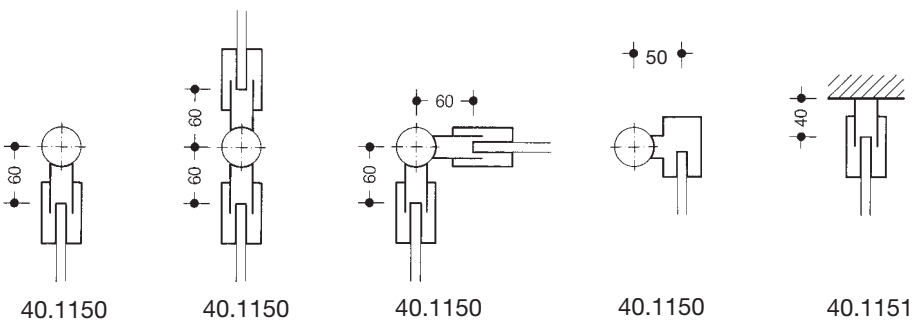
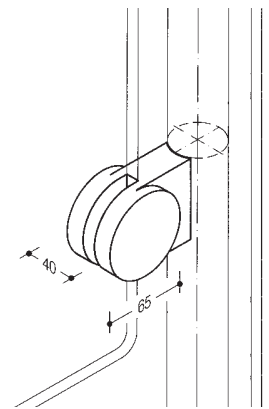

Panel Holder circum

Panel holders to clamp infill panels of 8 or 10 mm thickness, clamp screws require a torque of 12 Nm to be applied to each screw.

Panel holder made of zinc deacasting, stainless steel finish, to clamp infill panels of 8 or 10 mm thickness, like toughened glass or perforated stainless steel with large frame.

The top clamp holders are fitted with a locking pin (6 x 18 mm diameter) to avoid slippage of panels. Therefore two holes (12 mm diameter) are required in the infill panels.

A 2.5 mm gap between panel holder and infill panel should be allowed.

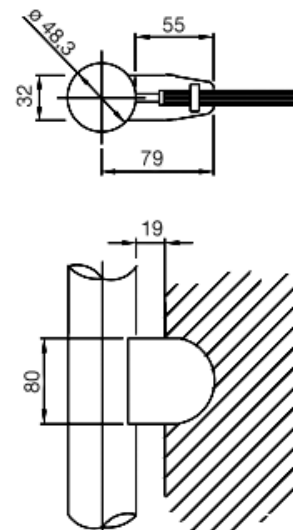

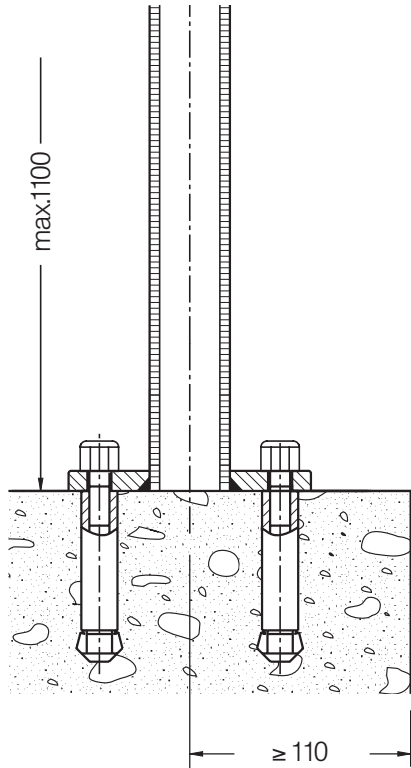

Circum Stainless Steel Platform Fixing Plate (surface mounting)

135 mm diameter x 10 mm thick surface mounting plate suitable for 48,3 mm diameter posts with a maximum rail height of 1100 mm.

Application: on treads, landings, upstand kerbs and ramps

Concrete thickness: 130 mm

Minimum distance from edge of concrete to centre of post: 110 mm

Drilling: 2 holes for the appropriate 12 mm anchors

Distance between holes: 100 mm

Anchoring in concrete: 12 mm diameter bolts and kemfix anchors

Anchoring in steel: bolts M12

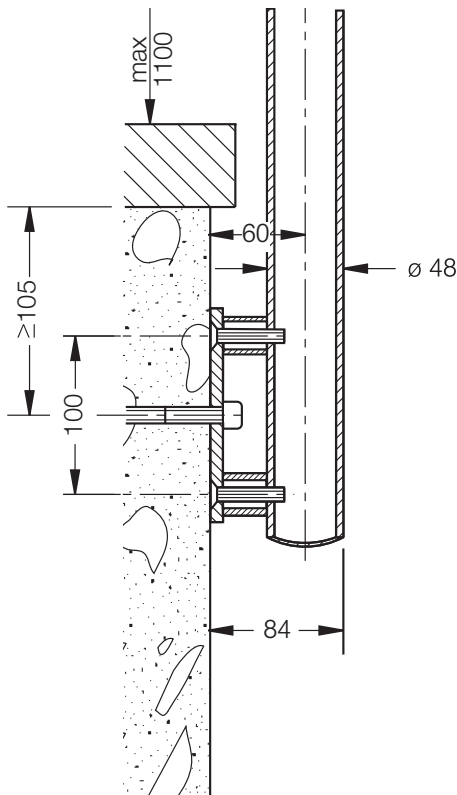
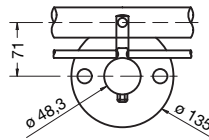

Circum Stainless Steel Side Fixing Plate

135 mm diameter x 10 mm thick surface mounting plate suitable for 48,3 mm diameter posts with a maximum rail height of 1100 mm.

Application: Stair strings, landing edges, upstand, kerbs and walls.

Concrete thickness: 130 mm

Minimum distance from edge of concrete to centre of mounting plate: 105 mm

Drilling: 2 holes for the appropriate 12 mm anchors

Distance between holes: 100 mm

Anchoring in concrete: 12 mm diameter bolts and kemfix anchors

Anchoring in steel: bolts M12

Minimum distance from edge of concrete to centre of plate: 60 mm

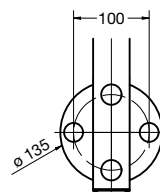

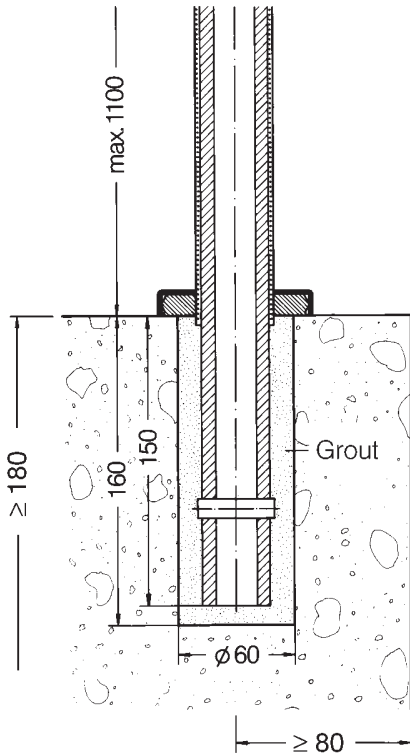

HEWI Post with Fastening Type 1.2

(Concrete Anchor)

Continuous steel core with cross lug.

Rose to cover core drilled hole.

For 40 mm ϕ posts with max. rail height of 1100 mm

Application: on treads, landings and curbs

Anchoring material (floor construction):

Minimum concrete strength B 25 (25 N/mm²)

A reduction of the min. distance from edge of concrete to centre of post might be possible, but each individual situation must be approved by a qualified technician.

Note: check if min. distance from the edge of the tread or landing reduces the min. required stair width applicable to Building Regulations.

Filler: non-shrink grout

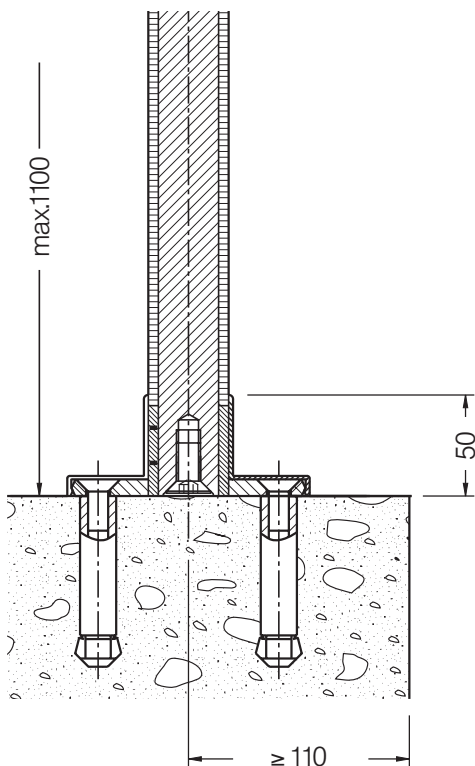

HEWI Post with Fastening Type 1.3

(Surface fastening)

Surface mounting with $\phi 120$ mm x 10 mm steel base plate with steel socket and polyamide outer cover.

Continuous steel core into steel socket secured with M12 screw and four M6 set screws to prevent vertical and horizontal movement.

For 40 mm ϕ posts with max. rail height of 1100 mm

Concrete thickness: ≥ 130 mm

Minimum distance from edge of concrete to centre of post: ≥ 110 mm

Drilling: three holes to appropriate 10 mm anchors

Distance between holes: 78 mm

Anchoring in concrete: 10 mm screws and anchors

Anchoring in steel: bolts M10

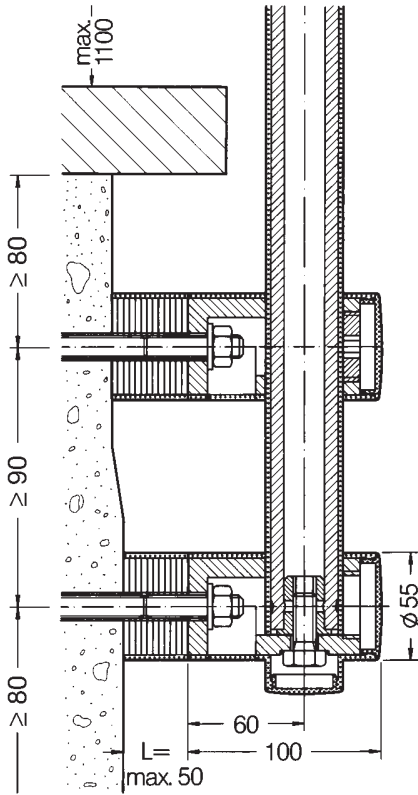

HEWI Post with Fastening Type 1.4

(Two point side mount)

Side mounting with two fastening points.

Continuous steel core into lower fastening point, secured with M12 bolt and clamping plate to prevent vertical and horizontal movement.

Application: on stringers, landings and walls

Anchoring foundation: concrete B 25, steel, wood (bolt through)

Concrete thickness: ≥ 250 mm

Minimum distance from edge of concrete to centre of post: ≥ 80 mm

A reduction of the min. distance might be possible, but each individual situation needs to be approved by a qualified HEWI technician.

Note: Standard dimension from wall to centre of post = 60 mm. Fastening points can be extended up to 50 mm; therefore, the maximum tread or landing overhang can be 85 mm.

Drilling: two holes for appropriate 12 mm anchors

Distance between holes: ≥ 90 mm min.

Anchoring in concrete: appropriate chemical anchor M12 (or expansion anchor M12)

Anchoring in steel: appropriate bolts M12

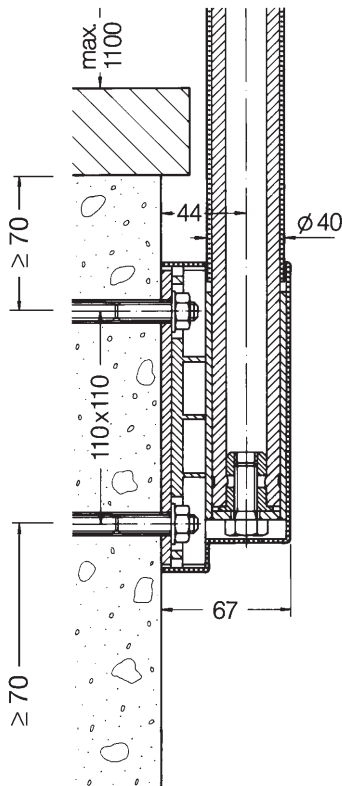

HEWI Post with Fastening Type 1.5 (160 mm x 160 mm)

(Four point side mount)

Side mounting with four fastening points.

Continuous steel core into steel sleeve, secured with M12 bolt and M6 set screw to prevent vertical and horizontal movement.

For 40 mm \varnothing posts with max. rail height of 1100 mm

Application: on stringers, landings and walls

Anchoring foundation: concrete B 25, steel, wood

Concrete thickness: ≥ 250 mm

Minimum distance from edge of concrete to centre of post: ≥ 70 mm

A reduction of the min. distance might be possible, but each individual situation needs to be approved by a qualified HEWI technician.

Note: the max. overhang on treads and landings to be 20 mm

Drilling: four holes to appropriate 10 mm anchors

Min. distance between fastening points: 110 mm x 110 mm

Anchoring in concrete: chemical anchor M10

Anchoring in steel: appropriate bolts M10

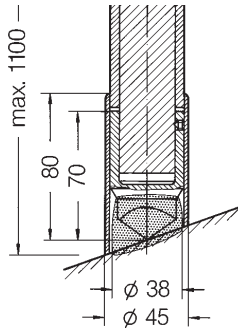

HEWI Post with Fastening Type 1.7

(Welded fastening)

Surface mounting with welded steel socket.

Continuous steel core into steel socket, secured with four M6 set screws to prevent vertical and horizontal movement. For 40 mm \varnothing posts with max. rail height of 1100 mm.

Application: steel stringers and plates

Minimum stringer/plate width: ≥ 51 mm

Weld requirements:

Multiple pass weld w/chipping to achieve required build up of weld.

Certified welder required to execute this joint.

Nylon must be protected by wet towels during welding.

Joint to be filled with petroleum jelly after welding.

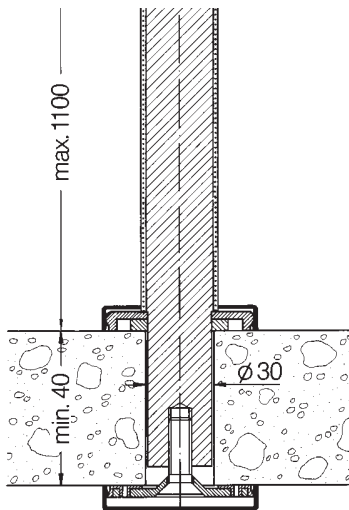

HEWI Post with Fastening Type 2.2

(Through bolt fastening)

Continuous steel core and two steel roses.

Rose to cover core drilled hole.

Application: on open tread stairs and landings with access to the underside

Anchoring material (floor construction):

concrete, marble, hardwood, steel

Thickness of floor or tread: ≥ 40 mm

Minimum distance from edge of concrete to centre of post: ≥ 70 mm

A reduction of the min. distance might be possible, but each individual situation needs to be approved by a qualified HEWI technician,

Note: check if min. distance from the edge of the tread or landing reduces the min. required stair width.

Core drilling: 30 mm \varnothing

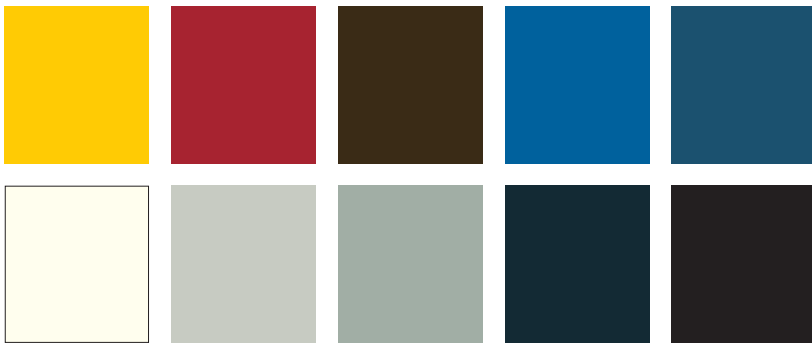

The HEWI Colour System

Freedom of design

HEWI offers all its polyamide hardware products in 10 colour options. Whether strong accentuation, elegant styling or a combination of shades of grey – HEWI colour options enable the desired effect to be achieved in any interior context.

HEWI Basic colours

Buttercup yellow (13), ruby red (33), coffee brown (80), ultramarine blue (53), steel blue (50).

HEWI Neutral colours

Pure white (99), light grey (97), stone grey (95), anthracite grey (92), jet black (90).

Part M, Definitions 0.29 says:

When used to indicate the visual perception of one element of the building, or fitting within the building, against another means that there should be a difference in light reflectance value between the two surfaces.

The contrast should be between all aspects of the built environment, walls, ceiling, architrave, doors and floor.

Many people who have limited vision still have the ability to see some shapes and colours, research carried out by Reading university - partly sponsored by HEWI, shows clearly the light reflection values (LRV) which give adequate visual contrast between door furniture and the door.

A detailed report and helpful colour contrast palette is available free of charge upon request.

- Technical advice from our fully qualified staff during preliminary design stages
- The total package quotation can be produced from architects drawings, bills of quantities or by ourselves taking site dimensions
- Preparation of specification and bills of quantities if required
- Site measurements taken by our project managers
- CAD fabrication drawings produced for approval
- Site fixing programme agreed with contractor
- All materials are transported in stout packaging to provide protection during transportation whilst on site
- Installation carried out nationally by our qualified installers - coordinated by our contracts division
- Foam Rubber protection fitted to rails
- Templates made for accurate sizing of infill panels
- Designs and type of infills to clients choice
- Site acceptance sheet signed by our installer and contractor on completion

For more information please refer to our Contract's Division at:

Regent House
Bath Avenue
Wolverhampton
WV1 4EG

Phone: +44 1902 810075

Fax: +44 1902 810078

eMail: contracts.division@hewi.co.uk

An overview of our hardware products is provided in a separate information brochure "Hardware - Summary of Ranges", available on request or in our hardware catalogue.

Lever handles



Polyamide



Stainless steel



Pull handles

Polyamide | Stainless steel



Window handles

Polyamide | Stainless steel



Door Accessoires

Polyamide | Stainless steel



Cloakrooms

Polyamide

HEWI

Germany

HEWI Heinrich Wilke GmbH
Postfach 1260
D-34442 Bad Arolsen
Phone: +49 5691 82-0
Fax: +49 5691 82-319
international@hewi.com
www.hewi.com

Great Britain

HEWI (UK) Ltd
Contracts Division
Regent House
Bath Avenue
Wolverhampton
WV1 4EG
Phone: +44 1902 810075
Fax: +44 1902 810078
contracts.division@hewi.co.uk
www.hewi.com

www.hewi.de